



## CONSTRUCTION FEATURES

- All stainless cabinet
- Fully ventilated
- Superior technology
- Hygienic interior
- Self closing door
- Adjustable shelving
- Full length door handle
- Lockable door
- Digital controller
- Low running costs
- Easy fit door seal
- Castors fitted
- Auto defrost
- Interior light
- Insulation 60 mm
- High quality compressor



## MEASUREMENTS

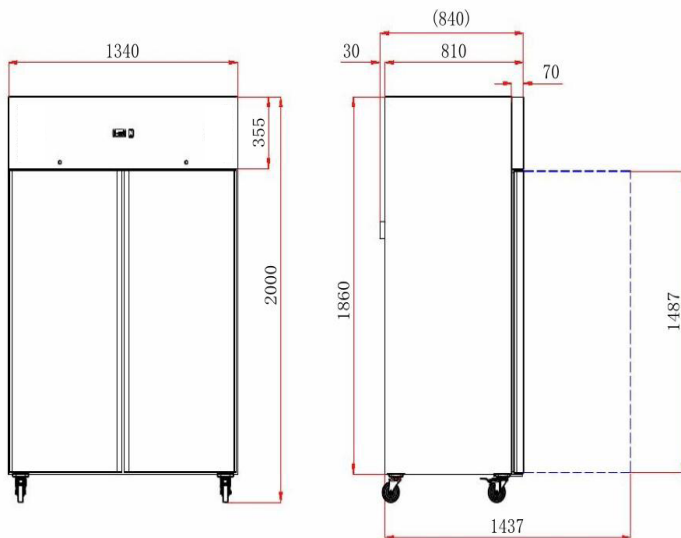

## TECHNICAL SPECIFICATION

Model	HVF 1270 Freezer
Dimensions	W1340 x D840 x H2000
Gross Capacity	1200 Litres
Shelves	6
Temperature	-18°C to -22°C
Compressor	CUBIGEL
Refrigerant	R290
Energy Class	D
Power	13 Amp Plug-in
Nett Weight	177 Kg.

## REFRIGERATION SYSTEM

- Refrigeration system uses R290 refrigerant to comply with up to date environmental law
- Automatic defrost
- The system is regulated and programmable by a Dixell electronic controller